

## ESM-HOLO FAQ's

**1. What is the construction of ESM-HOLO?**

*ESM-HOLO is made of 6 mil gloss holographic film. It has a permanent, general-purpose adhesive.*

**2. What sizes are available for ESM-HOLO?**

*ESM-HOLO is available in 15" x 75' and 30" x 75' rolls.*

**3. What types of inks is ESM-HOLO compatible with?**

*ESM-HOLO can be printed with Roland DG's eco-solvent, UV, and resin inks.*

**4. Since the media is thick, do I need a special blade to cut the material?**

*The 60° blade works best on thicker media. Here's a [link](#) to a blog about blade settings.*

**5. How much grams of force do I need to use for ESM-HOLO?**

*You will need to use approximately 100 - 300 grams of force to cut ESM-HOLO. Always perform a Cut Test on your printer/cutter to confirm the correct grams of force needed for ESM-HOLO. Here's a [link](#) to a blog about blade settings.*

**6. Are there special loading instructions for 15" wide rolls on my BN-20 Series printer?**

*Follow the User's Manual for "Loading Media" on pages 14 -18. **Pay close attention to make sure that the media edges are aligned under the pinch rollers on each side to avoid any error notices.***

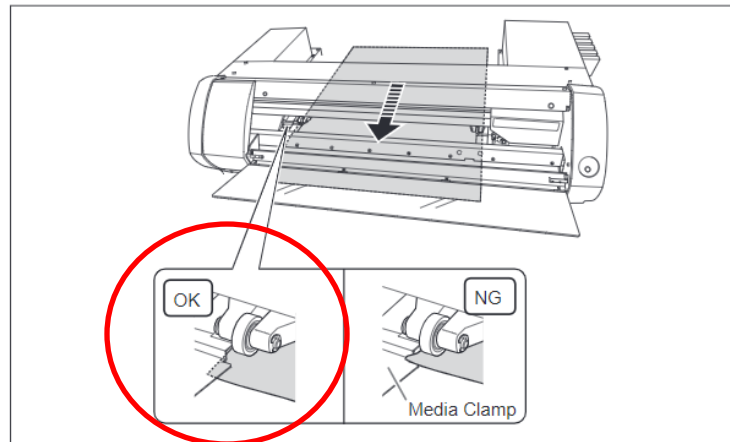

**schillers**

**DIGITAL PRINTER GROUP**

9240 Manchester Road • St. Louis, MO 63144

314-968-3650 • 800-366-7244

[dpg.schillers.com](http://dpg.schillers.com)

Imagine.

Roland DGA Corporation | 15363 Barranca Parkway | Irvine, CA. 92618-2216

800.542.2307 | 949.727.2100 | 949.727.2112 fax | [www.rolanddga.com](http://www.rolanddga.com)

**7. Are there profiles for ESM-HOLO?**

*Yes, there are profiles created for ESM-HOLO. You can download them from the Roland Profile Center. If you are unable to find one, please use Generic Vinyl profile in VersaWorks. If you have white ink and would like to use white ink as a layer, use Generic Clear Vinyl profile in VersaWorks. To get the best vibrant graphics, please select “Max Impact” in the Color Management drop-down menu.*

**8. Are there recommended images to use for ESM-HOLO?**

*Simple images with bold colors are best. If you’re not printing with white inks, then any white area in the graphics will be the holographic film showing through. Do not use graphics with special effects, i.e., shadows, gradations, etc. Below are examples of Simple vs. Complex Images.*



Simple Image (recommended)



Complex Image



Simple Image (recommended)



Complex Image

**9. Do I need to use an overlamine film with ESM-HOLO?**

*While it is not necessary to use one, you can use ESM-GLGF (GuardLam Gloss Overlamine Film) for extended durability. It is an optically clear overlamine that will not inhibit the holographic effects.*

**10. Why are there lines on the media every 12" or so?**

*During the embossing process, there are shim lines visible every 12" across the width of the roll.*

